



All Rights Reserved

Materials and specifications are subject to change without notice.
Featured machines in photos may include additional equipment.
See your XCMG dealer for available options.



XE150WB

Hydraulic Excavator



www.xcmg.com

XCMG Regional Departments:

Europe	(+86-516) 87739703 87739218 87739537	Africa	(+86-516) 87735009 87739222 87739283
West Asia & North Africa	(+86-516) 87739702 87739202 87739223	Central Asia	(+86-516) 87739236 87739239 87739538
Asia-Pacific	(+86-516) 87739128 87739500 87739529	America	(+86-516) 87739285 87739551 87739710

XUZHOU CONSTRUCTION MACHINERY GROUP IMP. & EXP. CO., LTD

Add: No.1, Tuolanshan Road, Xuzhou Economic Developing Zone, Jiangsu, China 221004

Fax: (+86-516) 87739230

E-mail: export@xcmg.com

Advanced Configuration

Ecological and Economical

- ▶ The in-line, water-cooled, high-pressure, and common rail engine can meet the National Stage III Emission Standard
- ▶ The excellent matching of hydraulic system and engine is more powerful and fuel saving
- ▶ Lower noise makes you more comfortable.

Multiple applications

- ▶ With high/low/slow gears provided, the vehicle can adapt to complex terrain with its super high traction
- ▶ Multiple additional configurations meet a variety of operating requirements

Intelligent Control

- ▶ Integrated control panel and large display screen provide multiple information
- ▶ Constant-speed cruise control reduces driving fatigue
- ▶ Undercarriage system with modular design improves vehicle's adaptability.

Comfortable operating experience

- ▶ The HVAC ensures the appropriate temperature
- ▶ Toughened glass cockpit with good safety view
- ▶ Detailed design concept improves comfort

Excellent after-sales service

- ▶ Global after-sales service system and quick response mechanism
- ▶ Real-time technical consultation and maintenance

Convenient maintenance

- ▶ Easy maintenance design, open the engine hood for no dead angle maintenance
- ▶ Electrically centralized lubrication makes daily maintenance easier

Safe and durable

- ▶ Forging technology are adopted in key positions
- ▶ Integrated electrical system runs reliably
- ▶ Waterproofing electrical plug-in components
- ▶ D-shaped frame and chassis reduce deformation



Ecological And Economical

▶ Equipped with a high-efficiency direct injection engine, it is designed to use the in-cylinder direct injection technology to make the fuel burn more fully and meet the environmental emission requirements without using exhaust gas recirculation (EGR) and aftertreatment (DPF). The overall cylinder displacement is increased, the friction power is lost, the structure is stronger and the noise is lower. Continuous and stable power output can be achieved at low speeds. Powerful torque meets hydraulic system requirements and enables faster duty cycles.



- ▶ The improved new-generation hydraulic system can take full use of the engine power, as well as improve the maneuverability and operational response speed, to achieve higher operational efficiency and operation security.
- ▶ The medium wheeled excavator comes standard with an automatic idle speed function that saves fuel.
- ▶ The use of a high static pressure low speed fan reduces additional fuel consumption and noise levels while improving cooling performance.



Comfortable And Reliable

▶ The newly designed cab enjoys a huge view and lower noise. In the cab, seats can be slid all around and be adjusted to a comfortable position relative to the joysticks and foot pedal. Integrated control panel, enlarged skylight and sun shade, comfortable foot pedal, easy-to-clean footpads, multiple storage boxes, heat/cold storage boxes, and adjustable steering column form a control environment that conforms to ergonomics. The air conditioning control system allows the operator to feel comfortable while working for hours.



- ▶ Adopt the dozer blade that can move in parallel and the assistant stabilizing outrigger to improve the stability of the machine support. The outrigger and dozer blade in contact with the ground are carefully designed to prevent damage to the asphalt pavement. The support of the contact surface is enlarged to further reduce the bearing pressure of the ground.
- ▶ The advanced wheel brake system makes the machine brake more effectively. It eliminates the rocking effect of the machine on the wheels when excavating. The transmission and axle integrated braking system can ensure the safety and meanwhile minimize the vibration of the whole machine, and effectively improve the braking stability.
- ▶ With high-sensitivity operation switches and buttons, it is easy to read the instrument information clearly, and it can work freely with the simplest control. Even carefully following the switch and the frequency they use, it is convenient for the operator to touch but does not affect the operation.



Intelligent Control

- ▶ The user can select the configuration of the rear view camera, so that the surrounding situation can be observed more intuitively. The large-size omni-directional rear view mirror under standard configuration meets the safety requirements of the operation.
- ▶ With smooth selector switch, you can easily and accurately control the travel function of the machine. Adopting the advanced power-shift transmission "POWER SHIFT" imported from ZF in Germany, it has two speed modes: high speed mode and slow speed mode.
- ▶ Undercarriage system with modular design: It can satisfy customer's different configurations of bucket storage rack, auxiliary outrigger, and dozer blades, meet customer's customized demands, and improve vehicle's adaptability.



Multiple Applications

- ▶ With first-rate digging force, the machine can be fully competent under complicated working conditions;
- ▶ Excellent driving performance: With high/low/slow gears provided, the vehicle can adapt to complex terrain with its super high traction;
- ▶ Ideal size and working range can meet transportation, driving, and construction requirements;



Maintenance And Service

- ▶ Easy maintenance: All kinds of maintenance filters are accessible on ground level.
- ▶ Large handrails and anti-skid measures make the maintenance of engine compartment safer and more convenient.
- ▶ The radiator and filter are easy to clean and replace due to their locations.
- ▶ Diesel filling pump makes it more convenient to fill daily fuel.
- ▶ Electrically centralized lubrication makes daily maintenance easier and more convenient.
- ▶ A wide range of after-sales service system, quick-response rescue mechanism to ensure that you use at ease



The XE150WB wheel hydraulic excavator is powerful, compact and flexible enough to handle a variety of working conditions. The ergonomic cab provides a comfortable working environment with a full range of careers; the world-class supporting drive motor and bridge box system make the driving ability outstanding and improve the passing ability of the whole vehicle. The product dimensions are in line with road regulations and transportation requirements. It plays an important role in airports, ports, oil fields, urban construction, farmland water conservancy, and rapid repair. The high cost performance can bring great value to customers. It can be widely used in small and medium-sized earthwork construction and garden maintenance projects such as municipal construction, highway bridges, house construction, road engineering, farmland water conservancy construction, and rural construction.



Standard Configuration

	Name of equipment	XE150WB
Engine	Engine model	QS84.5
	Emission level	National III
	Automatic preheating	
	Oil-water separator with water level indication sensor	
	Radial seal air cleaner	
	Fuel marker	
	Fuel breather valve	
	Electronic fuel speed control	
	Automatic idle speed	
	Auxiliary hydraulic valve	
Hydraulic system	Reverse rotation damping valve	
	Automatic rotation parking brake	
	Hydraulic buffer valve	
	Boom Priority Valve	
	Rotary logic valve	
	Hydraulic oil ISO VG 46	
	Rotary anti-sway valve	
	Gauge pressure monitoring	
	Fully adjustable mechanical suspension seat	
	Adjustable seat armrest	
Cab and interior trim	Seat belt (51 mm [2"] wide)	
	Openable windscreen with auxiliary device	
	Front windshield divided by 70/30 ratio	
	Double laminated windshield and other toughened windows	
	Sliding door upper window	
Bi-directional air outlet air conditioner with defroster (automatic type) (pressurization function)		

Cab and interior trim	Color liquid crystal display capable of displaying warning information, filter / liquid replacement information and working hours	
	Control handle	
	Travel control pedal with detachable manual control lever	
	Two stereo speakers	
	Beverage cup holder	
	Coat and hat hook	
	Cleanable floor mat	
	Air conditioning system	
	High and low gears shift	
	One-key boost mode	
Safety and security configuration	Top sunroof	
	Intermittent multi-gear wiper	
	Cup holder/envelope	
	Cold and warm storage box	
	Radio receiver	
	Driving door locks and cabin locks	
	Alarm horn	
	Isolation plate between engine and oil pump chamber	
	Rear window emergency exit	
	Battery circuit breaker	
Boom and arm retaining valve		
Safety and security configuration	Explosion-proof valve for boom and arm pipeline	
	Overheat alarm	
	Safety handrails and pedals	
	Rotary alarm lamp	
	Anti-skid plate/anti-skid paste	
	Hydraulic safety locking lever	
	Emergency escape hammer	

Safety and security configuration	Left and right rearview mirrors
	Powershift transmission
	Tire fender
Chassis system and shield	Undercarriage traction ring
	10.00-20 tyre
	Dozer blade
	Outrigger and dozer blade guard
	Buffer cylinder
Equipment	Boom 4.6m
	Arm 2.1 m
	0.58M3 Strengthened Bucket
Electrical system	Battery (2×750CCA)
	70A alternator
	4.8 kW starter motor
	Travel alarm
	24V cigarette lighter
	Camera
	5V USB interface
Lighting lamp	Right and left boom work lights
	Cab interior lighting
	Front working light installed on cab top
	Rear working light installed on cab top
	Headlights installed in front of the turntable
	Steering lights installed on the left and right sides of the turntable
	Rear headlights installed behind the counterweight
Technology	Intelligent control system
	Data link socket

Optional Configuration

	Name of equipment	XE150WB
Engine	Oil-water separator with heater (24V)	
	Oil bath type air prefilter	
	Coolant heater (fuel type)	
	Rapid Refueling system	
Hydraulic system	Hydraulic oil ISO VG 32, 68	
	Pressurized cab	
Cab and interior trim	Air suspension seat with cushion heating	
	Retractable seat belt (51 mm [2 "] wide)	
	Vehicle mounted oxygen supply device	
	Fire extinguisher	
	Reserve switch for working aids	
	Electric sunshade curtain	
Safety and security configuration	Engine Emergency Stop Switch	
	Counterweight rearview mirror	
	Falling object protective structure (FOPS)	
Chassis system and shield	Single tyre	
	Outrigger assembly	
Equipment	Arm 2.5 m	
	Quick coupler	
	Hydraulic breaker	
	Hydraulic thumb pliers	
	Ripper	
	Vibratory plate compactor	
	Hydraulic shear	
	Grapples	
	High frequency crusher	

Equipment	Clamshell bucket
	Scrap grapple
	Screening bucket
	Pipe grab
	12V cigarette lighter
Electrical system	12V power interface
Lubrication system	Electric self-lubricating system

Main Specifications

Item	unit	Main specifications	
Model	/	XE150WB	
Operating Weight	Kg	14000	
Bucket capacity	m ³	0.58	
Engine	Model	QSB4.5	
	Direct injection	√	
	Four strokes	√	
	Water cooling	√	
	Turbocharging	√	
	Air-to-air intercooler	√	
	No. of cylinders	4	
	Rated power/speed	kw/rpm	104/2000
	Maximum torque/speed	N.m/rpm	586/1500
	Displacement	L	4.5
Main Performance	Travel speed(H/L)	km/h	30/11
	Swing speed	r/min	12
	Gradeability	°	≤35
	Ground pressure	kPa	/
	Bucket digging force	kN	95
	Arm digging force	kN	72
	Maximum tractive force	kN	77

Item	unit	Main specifications	
Hydraulic system	Main pump	/	
	Rated flow of main pump	L/min	2×160
	Main safety valve pressure	MPa	34.3
	Travel system pressure	MPa	34.3
	Swing system pressure	MPa	24.5
	Pilot system pressure	MPa	3.9
Oil Capacity	Fuel tank capacity	L	250
	Hydraulic tank capacity	L	135
	Engine oil capacity	L	11
Standard	Length of boom	mm	4600
	Length of arm	mm	2100
	Bucket capacity	m ³	0.58
Optional	Length of boom	mm	/
	Length of arm	mm	/
	Bucket capacity	m ³	0.24*0.76

Dimensions

Item	Unit	Parameters
A Overall length	mm	7714
B Overall width	mm	2496
C Overall height	mm	3180
D Clearance under counterweight	mm	1230
E Min. ground clearance	mm	355
F Tail turning radius	mm	2300
G Wheel base	mm	2800
H Tread width	mm	1920
I Width of platform	mm	2490
J The distance from front axle to the rotary center	mm	1700
K Hood height	mm	2430

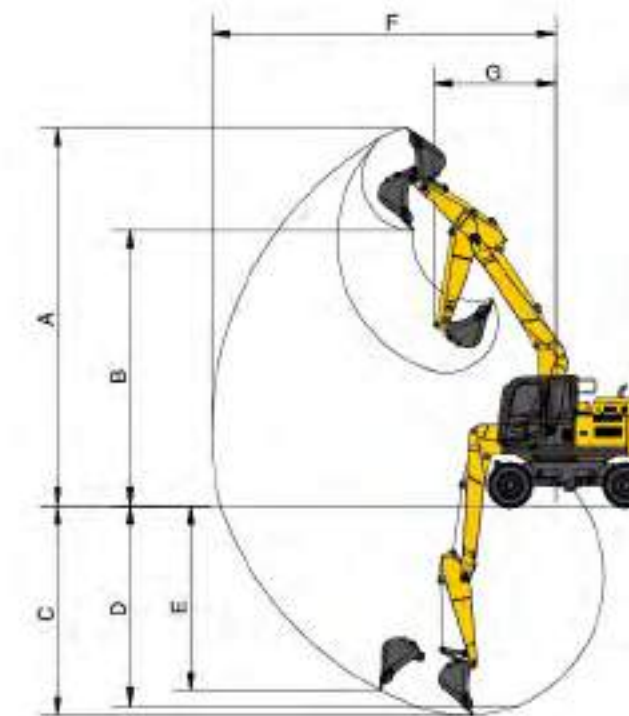
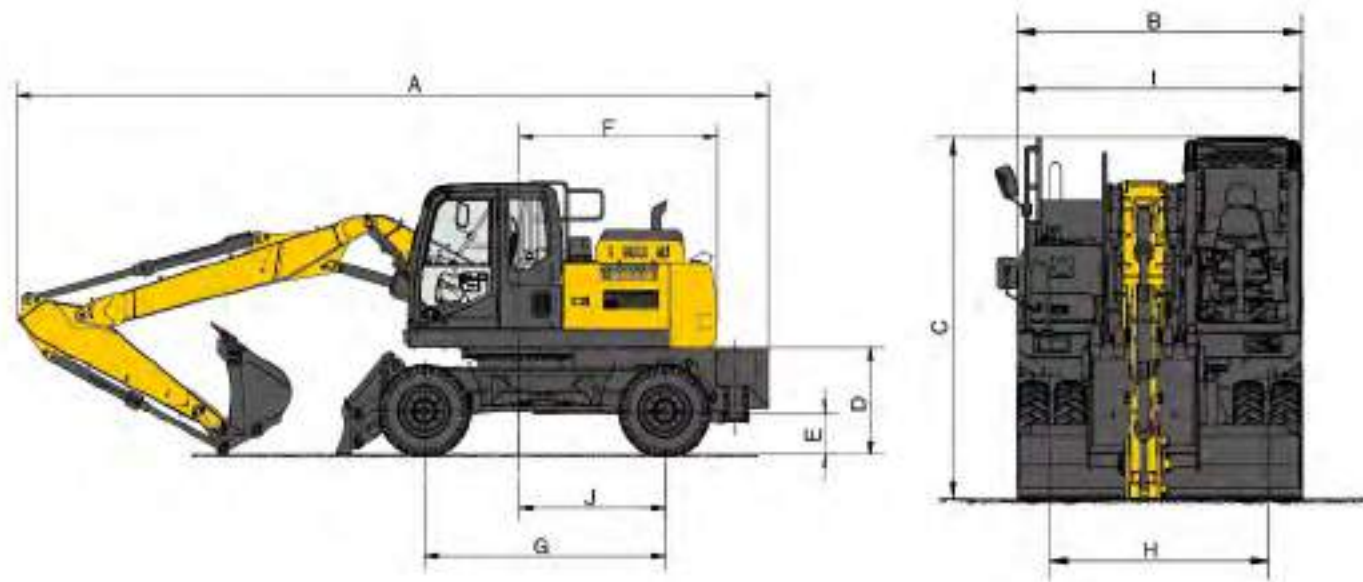

Working Range

Item	Unit	Parameters
A Max. digging reach	mm	7780
B Min. swing radius	mm	7570
C Max. digging height	mm	8190
D Max. dumping height	mm	5855
E Max. digging depth	mm	4630
F Maximum depth cut for 2240mm(8 ft) level bottom	mm	4325
G Max. vertical wall digging depth	mm	4150

Lifting capacity

Lifting point height (m)	Rated lift capacity – Straight ahead (back) (kg)				Rated lift capacity – over-side (kg)			
	Lifting point radius (m)			Lifting capacity at maximum radius	Lifting point radius (m)			Lifting capacity at maximum radius
	1	3	5		1	1	5	
7.153				*3530				*3530
6.5				*3260				*3260
6		*4200		*3145		*4200		*3145
4.5	*5745	*4915	*3045	*3030	*5745	*4915	*3045	*3030
3		*5885	*4525	*3135	5120	3290	2940	
1.5		*6290	*4710	*3460	4880	3195	2830	
Ground		*6330	*4575	*4135	4745	3140	2970	
-1.5	*7835	*5585		*4200	*7835	4735		3515

Capacities marked with an asterisk(*) are limited by hydraulic capacities.